

# NCV7451 System Basis Chip Evaluation Board User's Manual



ON Semiconductor®

[www.onsemi.com](http://www.onsemi.com)

## NCV7451V1GEVB

### Introduction

This document describes the evaluation board for the ON Semiconductor system basis chip (SBC) NCV7451 containing a CAN-FD transceiver, 5 V / 250 mA LDO regulator and local wakeup comparator. The board provides basic connections for a device evaluation.

### Evaluation Board Features

- One-row Pin Header Providing Access to All the Device Pins, Enables Easy Insertion of the Evaluation Board into a more Complex Application Setup
- Standard CAN Termination
- Position for Optional ESD Protection
- WAKE Pin External Components
- LED for RSTN Signal Activity Indication
- Jumpers for Configuration Signals

## EVAL BOARD USER'S MANUAL

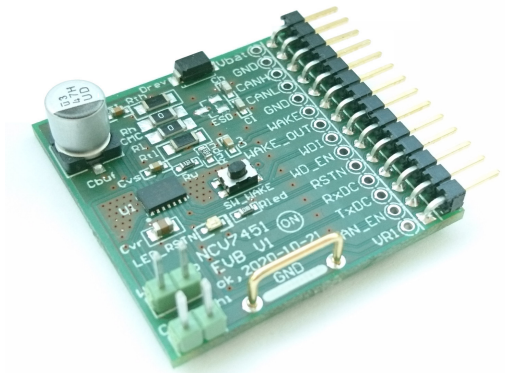

### SCHEMATIC

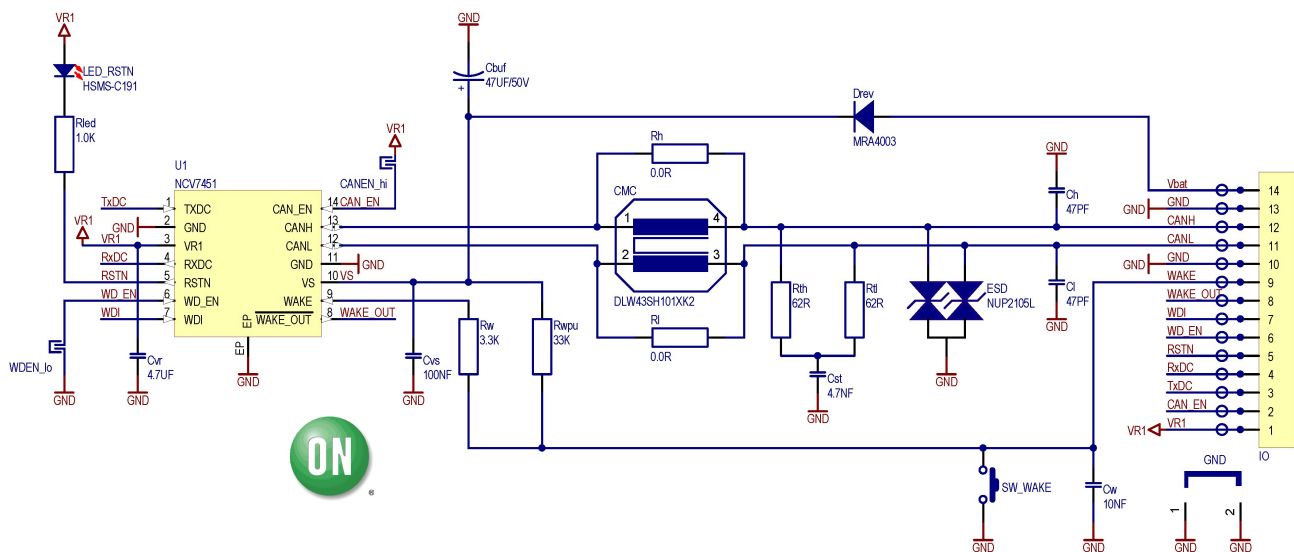

Figure 1. NCV7451 Evaluation Board Schematic

# NCV7451V1GEVB

## ABSOLUTE MAXIMUM RATINGS AND OPERATING RANGES

**Table 1. ABSOLUTE MAXIMUM RATINGS**

Rating	Pins	Min	Max	Unit
Battery Supply Voltage	Vbat	-40	40	V
LDO Regulator Output Voltage	VR1	-0.3	6 or VS+0.5 V (whichever is lower)	V
Digital Inputs / Outputs Voltage	TxDC, RxDC, EN_WD, EN_CAN, WAKE_OUT, WDI, RSTN	-0.3	VR1+0.3 V	V
CAN Bus Line Voltage	CANH, CANL	-40	40	V
Local Wakeup Input	WAKE	-40	40	V
NCV7451 Junction Temperature		-40	+150	°C
Board Temperature		-40	+125	°C

Stresses exceeding those listed in the Maximum Ratings table may damage the device. If any of these limits are exceeded, device functionality should not be assumed, damage may occur and reliability may be affected.

**Table 2. RECOMMENDED BOARD OPERATING CONDITIONS**

Rating	Pins	Min	Max	Unit
Battery Supply Voltage	Vbat	6	18	V
LDO Regulator Output Voltage	VR1	4.9	5.1	V
LDO Regulator Output Current	I(VR1)	0	250	mA
Digital Inputs / Outputs Voltage	TxDC, RxDC, EN_WD, EN_CAN, WAKE_OUT, WDI, RSTN	0	5	V
CAN Bus Line Voltage	CANH, CANL	0	5	V
Local Wakeup Input	WAKE	0	Vbat	V
NCV7451 Junction Temperature		-40	+150	°C
Board Temperature		-40	+125	°C

Functional operation above the stresses listed in the Recommended Operating Ranges is not implied. Extended exposure to stresses beyond the Recommended Operating Ranges limits may affect device reliability.

### OPERATIONAL GUIDELINES

NCV7451 evaluation board allows easy evaluation of NCV7451 system basis chip. It provides connection to all the device's pins as well as positions for all the necessary

CAN bus external components.

Configurations and assembly options are listed in Table 3.

For more information please check NCV7451 transceiver datasheet at [www.onsemi.com](http://www.onsemi.com).

**Table 3. ASSEMBLY OPTIONS AND CONFIGURATIONS**

Component	Default	Function
Rth, Rtl, Cst	2x 62R, 4.7 nF	CAN bus termination
ESD	-	Position for optional NUP2105 ESD protection
Ch, Cl	47 pF	ESD capacitors. Should be selected per application needs and ESD used
CMC	-	Optional common-mode choke
Rl, Rh	0 R	Bypass of CMC
CANEN_hi	Close	CAN_EN pin connection Open = CAN_EN weak internal pull-down = CAN transceiver disabled Close = CAN_EN connected to VR1 = CAN transceiver enabled
WDNEN_lo	Close	WD_EN pin connection Open = WD_EN weak internal pull-up current source (periodically activated) = watchdog enabled Close = WD_EN shorted to GND = watchdog disabled

# NCV7451V1GEVB

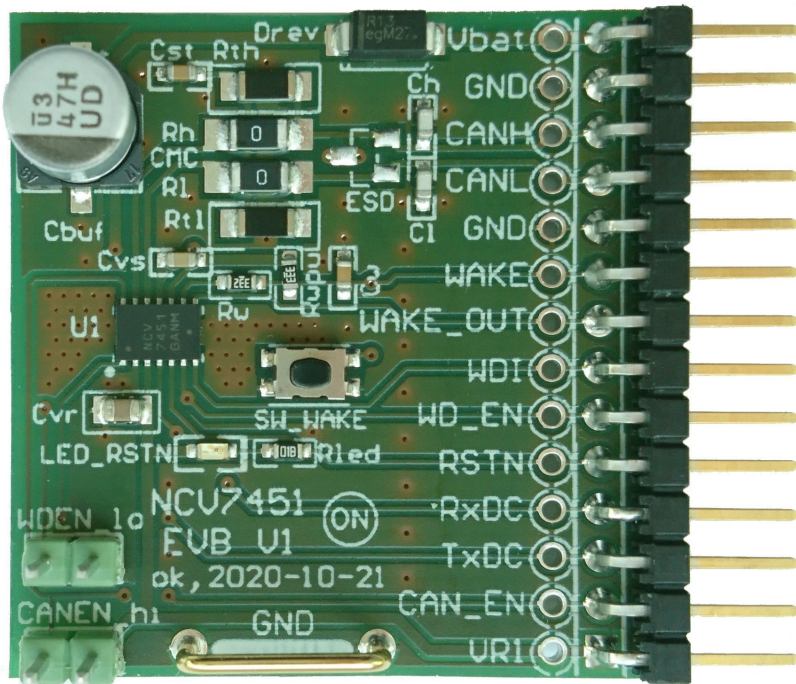

Figure 2. NCV7451 Evaluation Board Picture, Top Side

## PCB DRAWINGS

### Composite Drawings

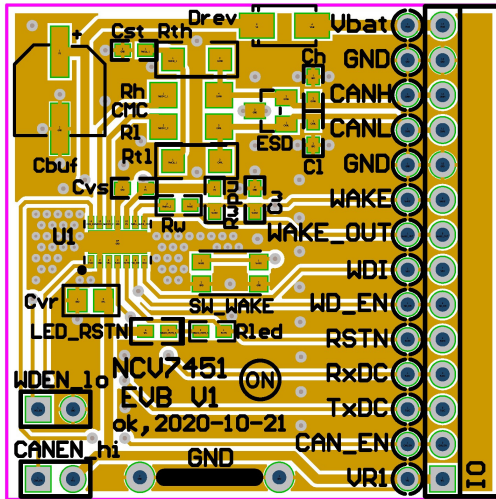

Figure 3. NCV7451 EVB PCB Top Drawing

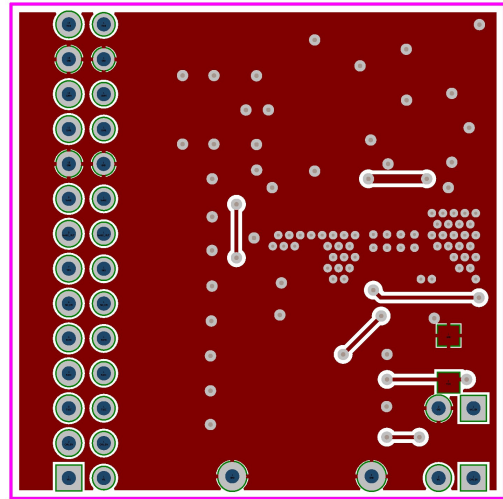

Figure 4. NCV7451 EVB PCB Bottom Drawing (Bottom View)

**onsemi**, **Onsemi**, and other names, marks, and brands are registered and/or common law trademarks of Semiconductor Components Industries, LLC dba "**onsemi**" or its affiliates and/or subsidiaries in the United States and/or other countries. **onsemi** owns the rights to a number of patents, trademarks, copyrights, trade secrets, and other intellectual property. A listing of **onsemi**'s product/patent coverage may be accessed at [www.onsemi.com/site/pdf/Patent-Marking.pdf](http://www.onsemi.com/site/pdf/Patent-Marking.pdf). **onsemi** is an Equal Opportunity/Affirmative Action Employer. This literature is subject to all applicable copyright laws and is not for resale in any manner.

The evaluation board/kit (research and development board/kit) (hereinafter the "board") is not a finished product and is not available for sale to consumers. The board is only intended for research, development, demonstration and evaluation purposes and will only be used in laboratory/development areas by persons with an engineering/technical training and familiar with the risks associated with handling electrical/mechanical components, systems and subsystems. This person assumes full responsibility/liability for proper and safe handling. Any other use, resale or redistribution for any other purpose is strictly prohibited.

**THE BOARD IS PROVIDED BY ONSEMI TO YOU "AS IS" AND WITHOUT ANY REPRESENTATIONS OR WARRANTIES WHATSOEVER. WITHOUT LIMITING THE FOREGOING, ONSEMI (AND ITS LICENSORS/SUPPLIERS) HEREBY DISCLAIMS ANY AND ALL REPRESENTATIONS AND WARRANTIES IN RELATION TO THE BOARD, ANY MODIFICATIONS, OR THIS AGREEMENT, WHETHER EXPRESS, IMPLIED, STATUTORY OR OTHERWISE, INCLUDING WITHOUT LIMITATION ANY AND ALL REPRESENTATIONS AND WARRANTIES OF MERCHANTABILITY, FITNESS FOR A PARTICULAR PURPOSE, TITLE, NON-INFRINGEMENT, AND THOSE ARISING FROM A COURSE OF DEALING, TRADE USAGE, TRADE CUSTOM OR TRADE PRACTICE.**

**onsemi** reserves the right to make changes without further notice to any board.

You are responsible for determining whether the board will be suitable for your intended use or application or will achieve your intended results. Prior to using or distributing any systems that have been evaluated, designed or tested using the board, you agree to test and validate your design to confirm the functionality for your application. Any technical, applications or design information or advice, quality characterization, reliability data or other services provided by **onsemi** shall not constitute any representation or warranty by **onsemi**, and no additional obligations or liabilities shall arise from **onsemi** having provided such information or services.

**onsemi** products including the boards are not designed, intended, or authorized for use in life support systems, or any FDA Class 3 medical devices or medical devices with a similar or equivalent classification in a foreign jurisdiction, or any devices intended for implantation in the human body. You agree to indemnify, defend and hold harmless **onsemi**, its directors, officers, employees, representatives, agents, subsidiaries, affiliates, distributors, and assigns, against any and all liabilities, losses, costs, damages, judgments, and expenses, arising out of any claim, demand, investigation, lawsuit, regulatory action or cause of action arising out of or associated with any unauthorized use, even if such claim alleges that **onsemi** was negligent regarding the design or manufacture of any products and/or the board.

This evaluation board/kit does not fall within the scope of the European Union directives regarding electromagnetic compatibility, restricted substances (RoHS), recycling (WEEE), FCC, CE or UL, and may not meet the technical requirements of these or other related directives.

FCC WARNING – This evaluation board/kit is intended for use for engineering development, demonstration, or evaluation purposes only and is not considered by **onsemi** to be a finished end product fit for general consumer use. It may generate, use, or radiate radio frequency energy and has not been tested for compliance with the limits of computing devices pursuant to part 15 of FCC rules, which are designed to provide reasonable protection against radio frequency interference. Operation of this equipment may cause interference with radio communications, in which case the user shall be responsible, at its expense, to take whatever measures may be required to correct this interference.

**onsemi** does not convey any license under its patent rights nor the rights of others.

LIMITATIONS OF LIABILITY: **onsemi** shall not be liable for any special, consequential, incidental, indirect or punitive damages, including, but not limited to the costs of requalification, delay, loss of profits or goodwill, arising out of or in connection with the board, even if **onsemi** is advised of the possibility of such damages. In no event shall **onsemi**'s aggregate liability from any obligation arising out of or in connection with the board, under any theory of liability, exceed the purchase price paid for the board, if any.

The board is provided to you subject to the license and other terms per **onsemi**'s standard terms and conditions of sale. For more information and documentation, please visit [www.onsemi.com](http://www.onsemi.com).

## ADDITIONAL INFORMATION

### TECHNICAL PUBLICATIONS:

Technical Library: [www.onsemi.com/design/resources/technical-documentation](http://www.onsemi.com/design/resources/technical-documentation)  
onsemi Website: [www.onsemi.com](http://www.onsemi.com)

ONLINE SUPPORT: [www.onsemi.com/support](http://www.onsemi.com/support)

For additional information, please contact your local Sales Representative at [www.onsemi.com/support/sales](http://www.onsemi.com/support/sales)