

Test Procedure for NCV7381B0V2EVB Evaluation Board

ON Semiconductor[®]



07/01/2019

Required Equipment

- Dual channel Oscilloscope
- Bench Power Supply
- Voltmeter
- Two NCV7381B0V2GEVB Evaluation Boards
- Two 12 V power supply adapters
- Two FlexRay bus cable assemblies

Test procedure Step1:

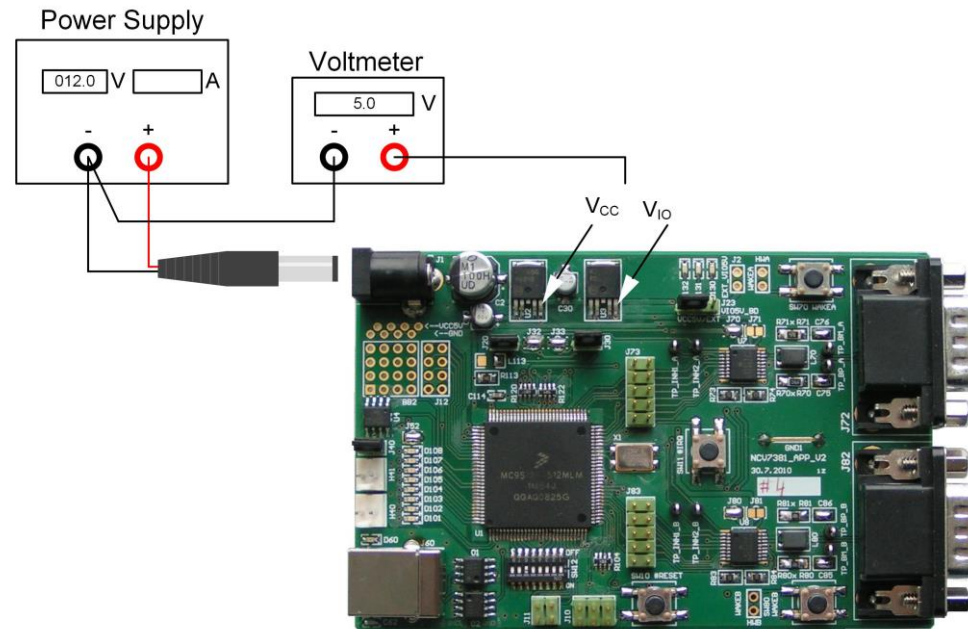

1. Set the boards to default configuration according to Jumpers and Default Configuration section.
2. Connect the setup as shown above.
3. Apply an input voltage, $V_{BAT} = 12\text{ V}$
4. Check I_{IN} , V_{CC} and V_{IO}

Table 1. Desired Results

$I_{IN} = 100\text{ mA to }130\text{ mA}$
 $V_{CC} = 4.9\text{ V to }5.1\text{ V}$
 $V_{IO} = 4.9\text{ V to }5.1\text{ V}$

Test procedure Step2:

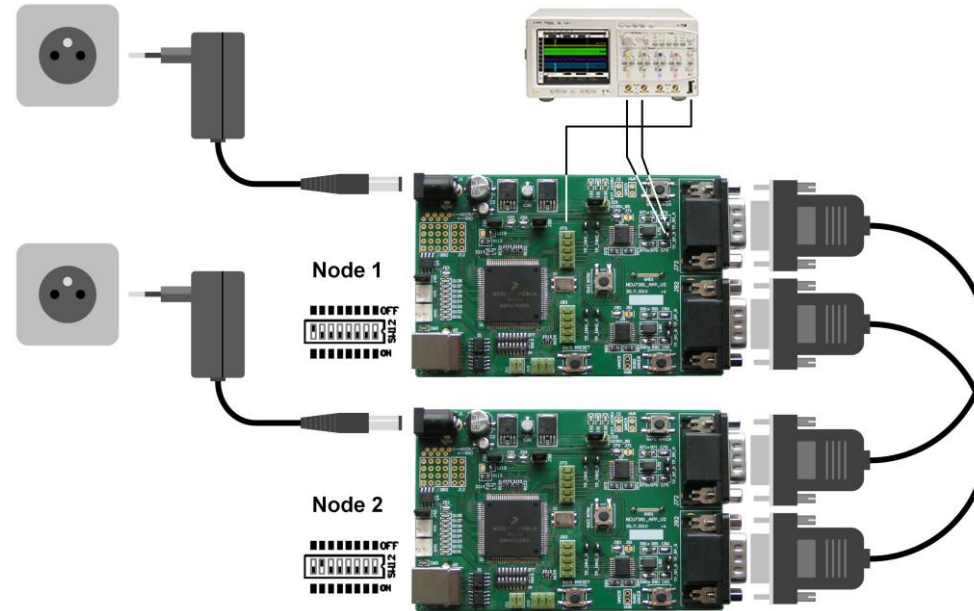

5. Connect two boards according to figure above.
6. Set a different board address on each board. One of the boards must be set with address 1 and is considered as Master Board. Node address is configurable by address switch (SW12).
7. Connect an oscilloscope to BP and BM test-points (Channel A or B).
8. After the power supply is applied, FlexRay communication should be automatically initialized, what should be signaled by blinking LED1 on both nodes. Communication on FlexRay bus should be visible on oscilloscope (BP and BM test-points).
9. Press and hold SW11 (#IRQ) on Node 1 for more than 5 seconds. Both nodes should be switched to SLEEP mode. FlexRay communication is stopped and voltage regulators V_{CC} and V_{IO} are disabled.
10. Press one of the Local Wakeup buttons (SW70, SW80) on any node. Both nodes should be woken up and the FlexRay communication should be restarted.

Jumpers and Default Configuration

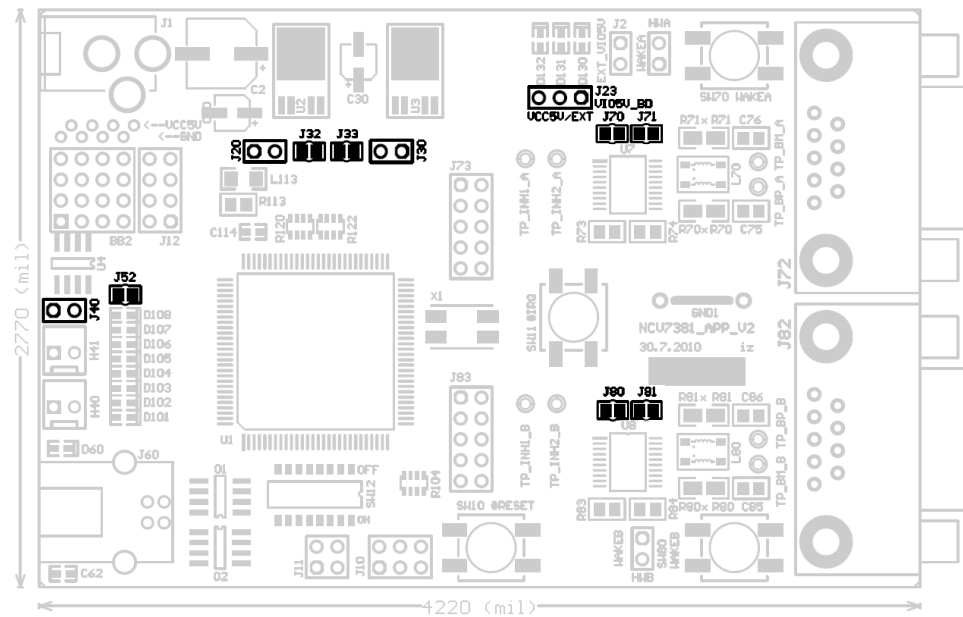

Figure 1. Jumpers and Soldering Straps

Table 2. 2-PIN JUMPER

		Open
		Closed

Table 3. 3-PIN JUMPER

1	2	3	
			Open
			Closed position 1-2
			Closed position 2-3

Table 4. JUMPER CONFIGURATION

Jumper	Function	Configuration	Description	Default
J20	MCU VCC 5 V State	Open	Controlled by bd_INH1_x	Open
		Closed	Always On	
J23	BD VIO power supply selection	Open	BD VIO Disconnected	Closed 1-2
		Closed 1-2	BD VIO Connected to MCU VCC	
		Closed 2-3	BD VIO - External VIO power supply	
J30	BD VCC State	Open	Controlled by MCU	Closed
		Closed	Controlled by bd_INHx_x	
J32	BD VCC Inhibit source (Ch A)	Open	bd_INH2_A	Closed
		Closed	bd_INH1_A	
J33	BD VCC Inhibit source (Ch B)	Open	bd_INH2_B	Closed
		Closed	bd_INH1_B	
J40	CAN bus termination	Open	Without Termination	Closed
		Closed	With 120 Ω Termination	
J52	General purpose LED	Open	LEDs Disabled	Closed
		Closed	LEDs Enabled	
J70	Bus Driver VBAT supply (Ch A)	Open	BD VBAT Disconnected	Closed
		Closed	BD VBAT Connected	
J71	Bus Driver VBUF supply (Ch A)	Open	BD VBUF Disconnected	Open
		Closed	BD VBUF Connected to BD VCC	
J80	Bus Driver VBAT supply (Ch B)	Open	BD VBAT Disconnected	Closed
		Closed	BD VBAT Connected	
J81	Bus Driver VBUF supply (Ch B)	Open	BD VBUF Disconnected	Open
		Closed	BD VBUF Connected to BD VCC	